

SOMMERKAMP[®]

CITIZENS BAND
TRASCEIVER

5 WATT 32 CHANNEL
FREQUENCY-SYNTHESIZED



MODEL
TS- 5632

SOMMERKAMP ELECTRONIC

CH-6815 LUGANO BOX 130
SWITZERLAND
TEL.091 688543 TELEX:79314

INSTRUCTION MANUAL

Copyright by www.sommerkamp-sprechfunk.de

CONTROL LOCATIONS:

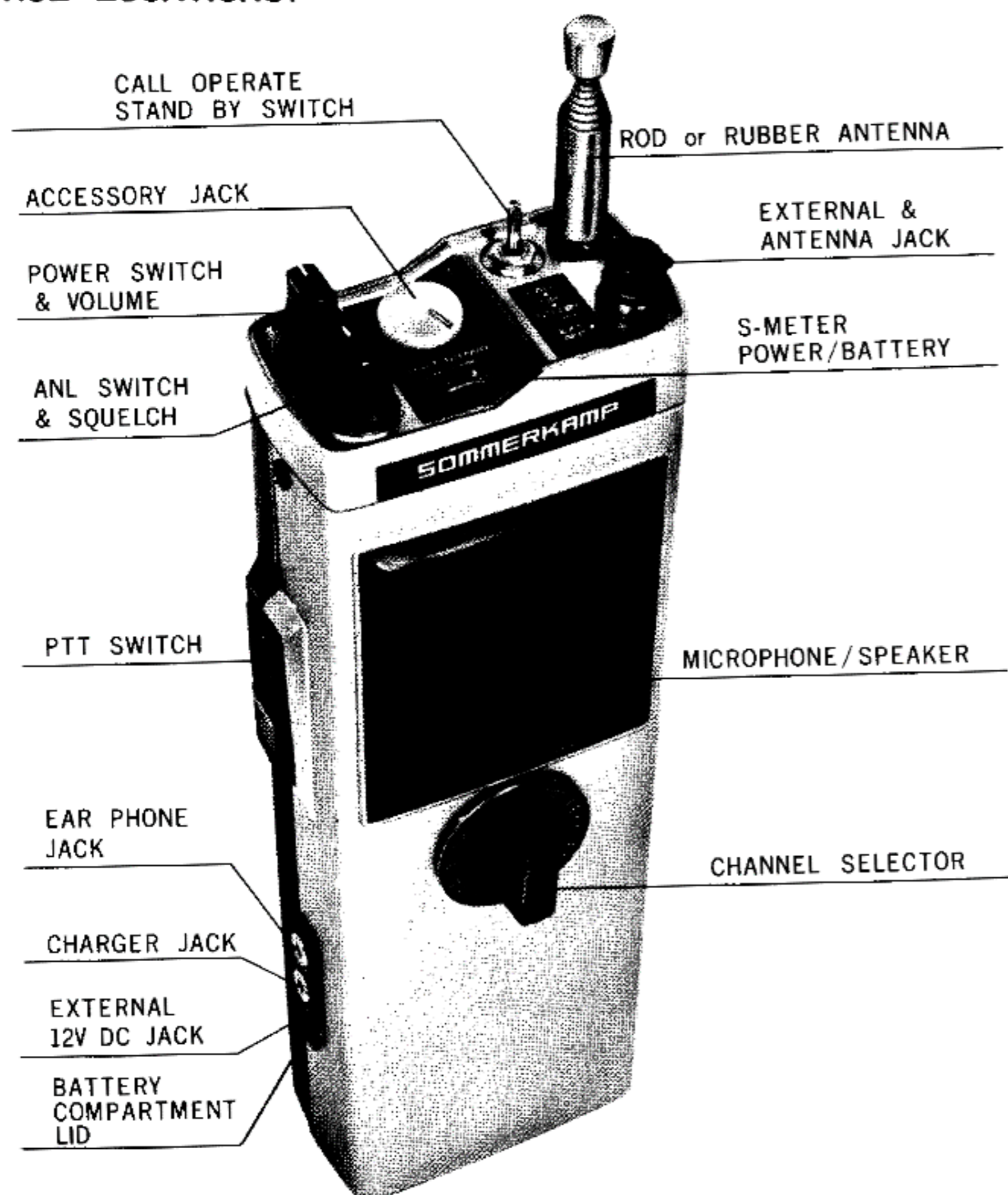

PACKING LIST:

Beside this manual, the carton shall contain the following items:

- 1 Transceiver TS-5632
- 1 Carrying case with shoulder strap
- 1 Earphone case with earphone
- 2 pcs dummy batteries inside the batterie case
- 1 shortening plug in the accessory jack

GENERAL DESCRIPTION

Your SOMMERKAMP TS-5632 transceiver has been designed for continuous heavy duty portable application. It can be operated with external antenna, power supply, headset, telephoneset incorporating automatic voice operated transmit/receive switching, short type rubber antenna, external selective calling with automatic answerback and many more.

GENERAL:

The transceiver is designed to operate with internal dry cells or rechargeable nickel-cadmium batteries such as N500AA set with the 12360 charger, or with an external 12V DC power supply such as NT30, or with an automobile battery. To prevent excessive battery drain, this transceiver has a stand-by switch in combination with the operate and call switch, which by a timing circuit and a switching transistor switches the receiver on for 2 seconds and off for 10 seconds. This device extends the battery life 6 times longer compared with continuous squelched stand-by operation. It is necessary, however, for a calling station to call by minimum 10-15 seconds before reception and contact is possible.

RECEIVER SECTION:

The receiver section is designed to receive amplitude modulated signals (AM/A3) in the 26.965 to 27.275 MHz. (11 meter) citizens band. The unique combination of low noise Field Effect Transistors (FET), double conversion, a combination of mechanical ceramic, and L/C filters, fully automatic noise limiter and a hifi quality speaker amplifier will give you exceptional reception quality in this fine piece of equipment.

In addition, the above combination of the latest technology provides you with a sensitivity and unwanted signal rejection and noise suppression available previously only in space and military communication equipment.

The power supply of the receiver section is stabilized by an extreme sharp cut-off Zener diode controlled series stabilizer to obtain the high sensitivity and unwanted signal rejection. The fully automatic series gate noise limiter, which virtually cuts off the audio output during ignition noise pulses, is defeatable to make even the weakest signal audible which otherwise would be cut off by the threshold level of the ANL switching diode.

The high squelch sensitivity is achieved by using a separate squelch detector and switching circuit with a carefully balanced hysteresis. The transformerless hifi quality audio power amplifier will drive any load between 32 ohms and indefinite such as internal speaker/microphone combination or external speaker/microphone or headset combinations having the above impedances.

The meter indicates the field strength during reception of a signal, and without signal the battery condition.

TRANSMITTER & MODULATOR SECTION:

The transmitter section is designed for continuous heavy duty transmission of amplitude modulated (AM/A3) signals in the 26.965 to 27.275 MHz. (11 meter) citizens band.

The transmitter consists of 2 crystal controlled oscillators incorporating 12 crystals. The output of these oscillators are synthesized in a class B mixer, followed by a double tuned filter, a class AB1 buffer, and a highly efficient collector-modulated class C driver and power output stage, coupled by series and pi-matching filters to the antenna jack and via a loading coil to the rod antenna.

The modulator consists of an input audio filter, integrated pre-and power amplifier and modulation transformer. This gives you the lowest possible modulation distortion and up to 100% modulation. The input is designed for 1 to 10K ohm dynamic microphone or 32 ohm speaker/microphone combination with a 1K ohm resistor in series.

RECEIVE/TRANSMIT SWITCHING:

The receive/transmit switching is done by a single pole, single throw micro switch with a life time of about 5 million operations and a combination of NPN and PNP switching transistors which also function in the receive mode as series voltage stabilizer. For remote switching, a parallel contact is provided at the accessory jack.

METER:

The combination meter provides you with the following functions:
During receive mode.....it indicates the incoming signal strength, and without incoming signals the battery condition.
During transmit mode... it indicates the output power.

STAND-BY:

The stand-by feature is incorporated to reduce battery drain during monitoring of a channel if no continuous communication is necessary.

POWER SUPPLY:

This transceiver is designed to operate with a nominal 12V DC power supply such as the internal dry cells or nickel-cadmium rechargeable batteries or an external power supply delivering at least 1.5 amperes. The equipment will operate from 10-16V DC without any damage.

UNPACKING AND CHECKOUT

Unpack the carton carefully and check for exterior damages.

Check that the volume control is in the OFF position, the squelch control in the ANL-OFF position and the standby-operate-call switch in OPERATE position.

Press the dent of the battery compartment lid and pull it out toward the bottom.

Lift out the battery holder and insert 8 dry cells into the holder as indicated, \oplus to \ominus , \ominus to \oplus pole. Leave the 2 dummy batteries in the holder as they are. If you use rechargeable batteries, insert 10 pieces of them in the same manner as above but remove the dummy batteries.

Snap the battery holder onto the snap connector provided and reinsert the holder into the compartment.

Replace the compartment lid by inserting it straight from the bottom up until it snaps in rightly.

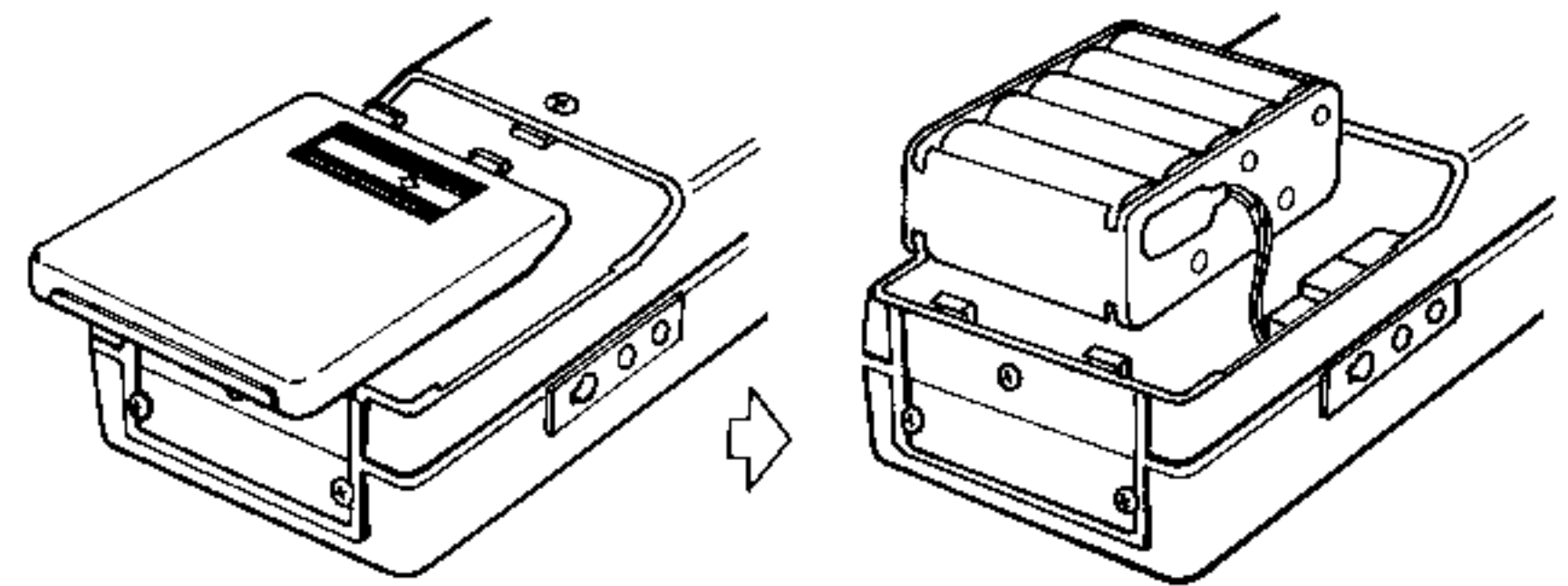

Then switch the transceiver ON by rotating the volume control clockwise and check that the meter needle moves into the red field. If the meter needle does not move, switch OFF immediately and check if the standby-operate-call switch is in the OPERATE position. If this is the case, open the battery compartment to remove the battery holder to ensure that the batteries are correctly inserted.

Now turn the volume control until noise is heard from the speaker. Then extend the rod antenna to the full length.

Switch the standby-operate-call switch to STANDBY. The noise from the speaker shall cease and the meter needle shall move to the black field. Within 10-15 seconds, the noise from the speaker shall be heard again and the meter needle moves to the red field. Wait for this cycle to repeat itself several times, then switch to OPERATE.

Rotate the channel switch step by step from channel 1 to 24 and check that some noise and/or signal is heard on each channel.

Push the push-to-talk (PTT) switch and observe the meter needle. It shall move into the red field. Now whistle into the speaker/microphone. The needle shall move a little. The same applies while pressing and releasing the call switch between operate and call.

Repeat this check on each channel from 1 to 24. This completes the checkout.

OPERATION

Extend the rod antenna completely and switch the transceiver ON by rotating the volume control clockwise.

Rotate the channel switch to the desired channel.

Adjust the volume control to a comfortable level.

Press the PTT switch and talk with a normal voice into the speaker/microphone from a distance of 5-10 cm. After completing your transmission, release the PTT switch, and the transceiver is ready for reception. Always remember that your opposite party cannot hear you while he is transmitting.

Adjust the squelch control so that the background noise just disappears during non-transmitting periods of your opposite party.

For stand-by operation, switch the STANDBY-OPERATE-CALL switch to STANDBY. Remember that the transceiver is 10 seconds OFF and 2 seconds ON and that your opposite party has to call for at least 10-15 seconds so that you can receive the call. Call either by voice or by the built-in tone call for this duration.

To answer the received call, switch to OPERATE, push the PTT switch and talk into the speaker/microphone.

To receive weak signals, turn the squelch control fully counter-clockwise so that the ANL is switched OFF.

To switch the transceiver OFF, turn the volume control fully counter-clockwise until a click is heard and the meter needle moves into the black field.

Important:

If you will not operate the transceiver for a long time, remove the batteries from the equipment so that they will not corrode and damage the transceiver. The same applies if you use the transceiver continuously with an external power supply.

ACCESSORIES

To install N500AA rechargeable nickel-cadmium batteries, follow the instructions under the Chapter UNPACKING AND CHECKOUT of this manual.

Charge the N500AA nickel-cadmium batteries by plugging the 1236 charger into the charger jack. Charge for 14 hours. It is not possible to operate the transceiver during charging.

To use the transceiver with the NT30AC power supply, plug it into the external power jack. For using a different power supply, it is recommended to select a low ripple, stabilized supply, delivering at least 1 ampere at 12V with a maximum output voltage of 16V.

To connect the transceiver to a 12V automobile battery, use an 1 ampere fuse in series with the positive wire.

Solder the positive wire to the center of the external power plug and the negative wire to its fin.

In case you use the transceiver with the RA1608 rubber antenna, screw out the telescopic antenna and replace it with the rubber antenna.

For private listening, plug the earphone into the earphone jack. The internal speaker will be disconnected.

To operate the transceiver with a 50 ohm external antenna, plug the coaxial connector into the external antenna jack and remove, if installed, the RA1608 rubber antenna.

ACCESSORY JACK

The 7-pin DIN standard accessory jack has the following internal connections:

- | | |
|--|------------------------------------|
| 1. Microphone input (Z 600-10K ohm) | 5. Audio output (Z 32 ohm-10K ohm) |
| 2. Transmit/Receive switching. | 6. +12V for VOX unit etc. |
| 3. Internal microphone output (Z 1K ohm) | 7. Ground return for 1-6. |
| 4. Internal speaker (Z 32 ohm) | |

Always operate the transceiver with the shortening plug inserted in the accessory jack, or with the following external connections:

1. External speaker or Headphone
2. Headset or Telefoneset with PTT

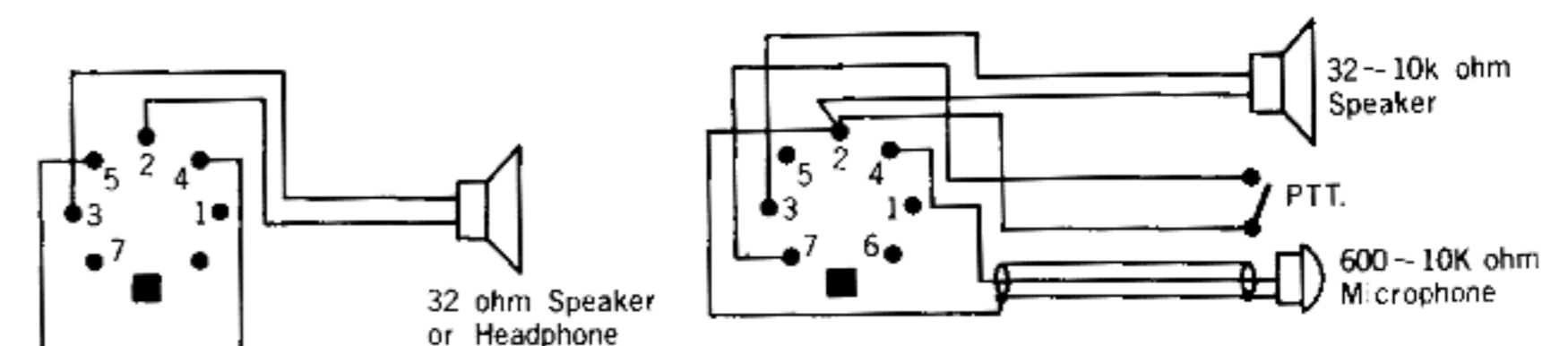

3. External microphone

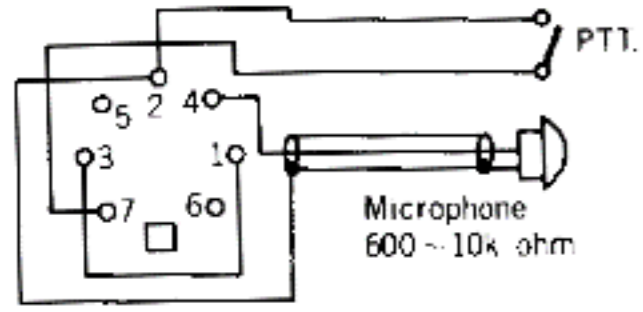

4. Headset or Telephoneset with VOX

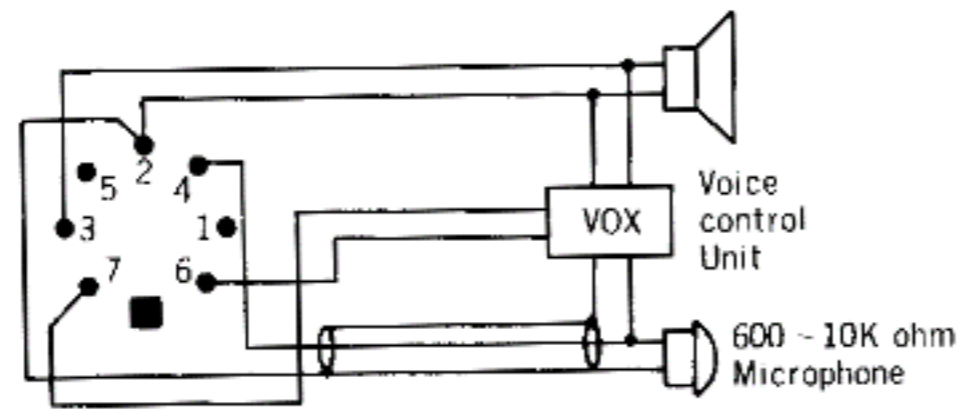

5. External microphone/speaker with PTT.

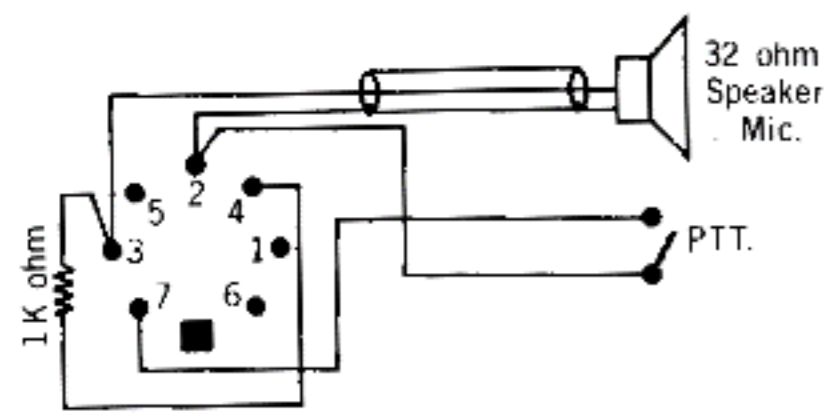

6. Internal connection

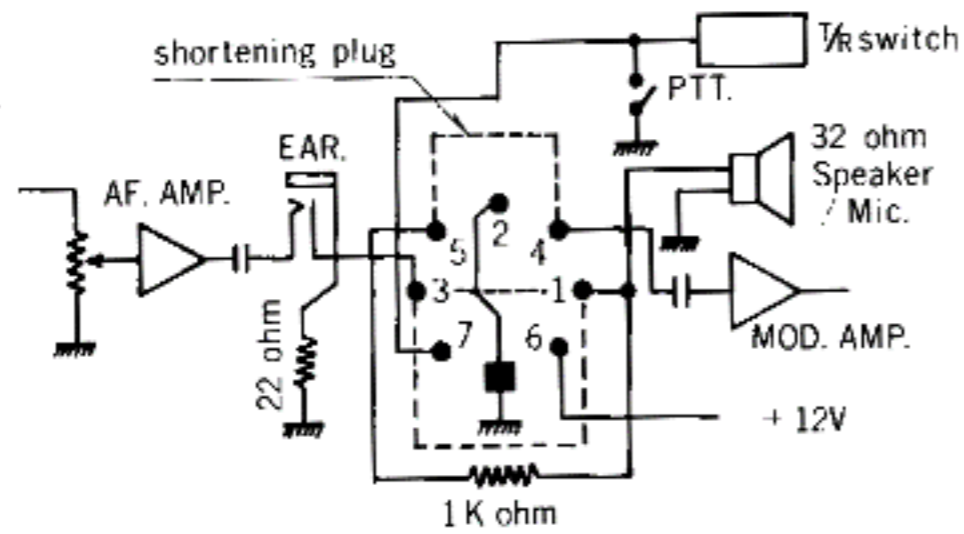

LIST OF CHANNEL FREQUENCY

CH.	FREQ. MHz	CH.	FREQ. MHz	CH.	FREQ. MHz
1	26.965	10	27.075	19	27.185
2	26.975	11	27.085	D	27.195
3	26.985	11A	27.095	20	27.205
A	26.995	12	27.105	21	27.215
4	27.005	13	27.115	22	27.225
5	27.015	14	27.125	E	27.235
6	27.025	15	27.135	F	27.245
7	27.035	C	27.145	23	27.255
B	27.045	16	27.155	G	27.265
8	27.055	17	27.165	24	27.275
9	27.065	18	27.175		

BLOCK DIAGRAM

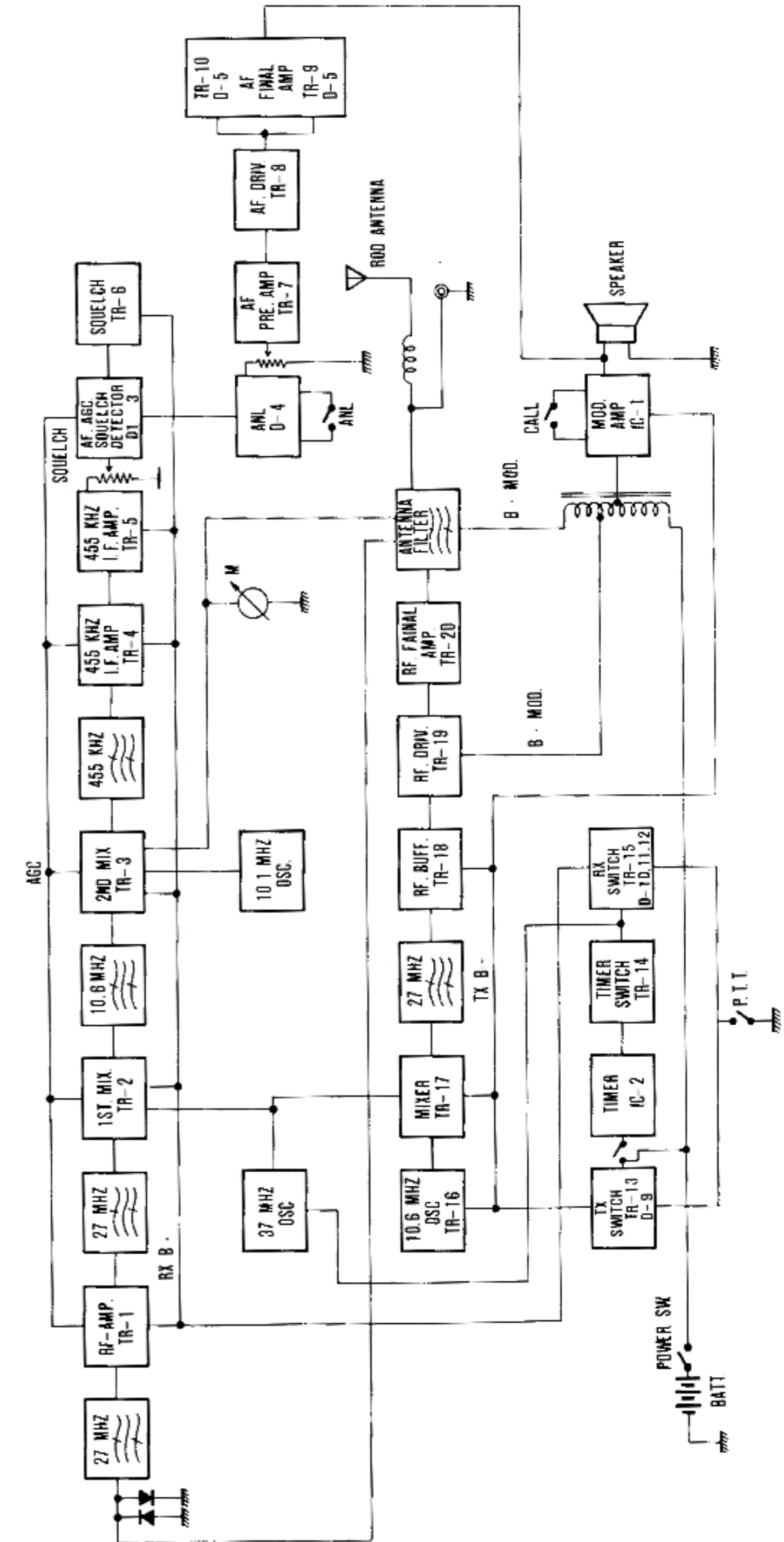

CIRCUIT DIAGRAM

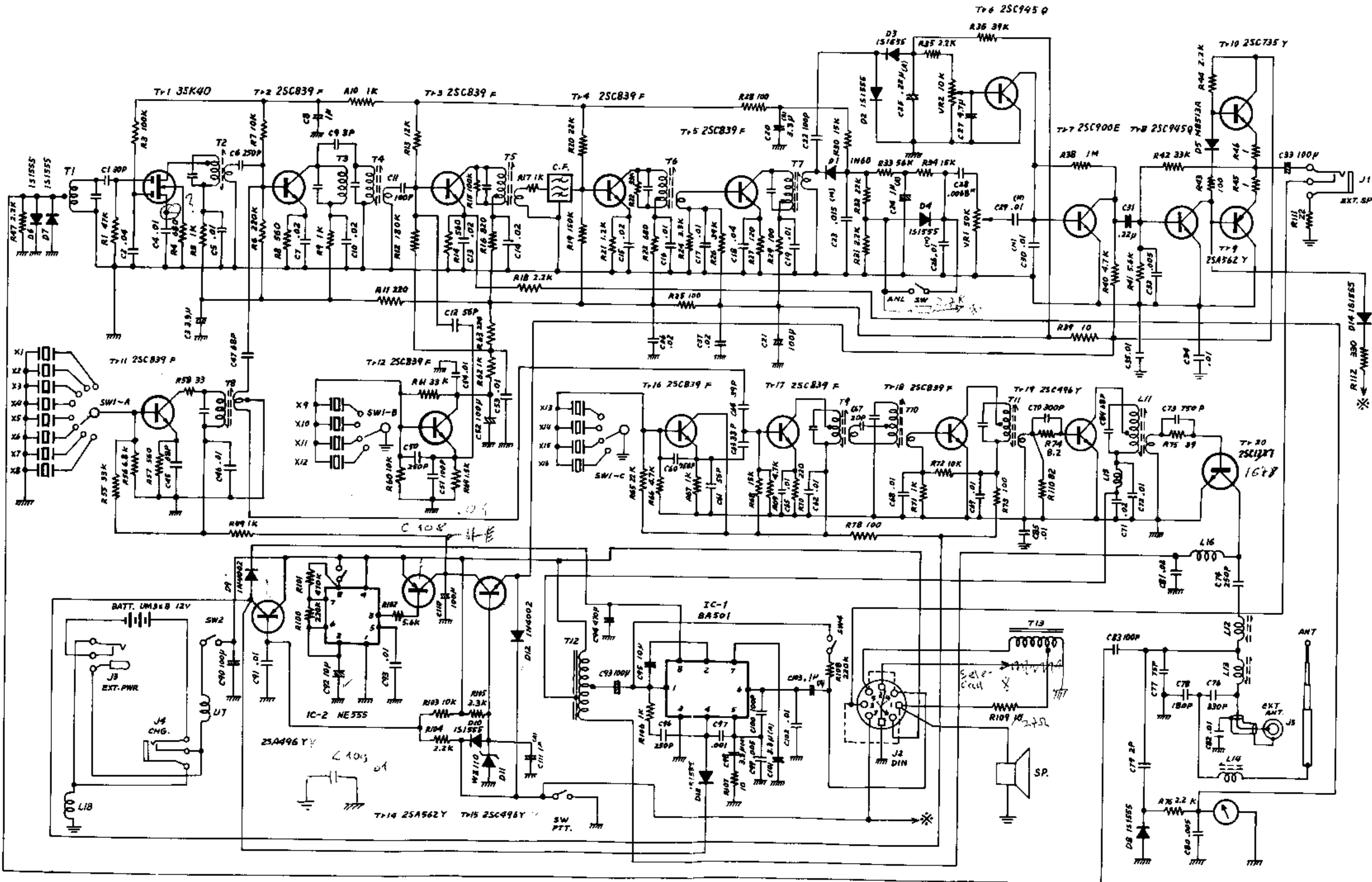

WIRING LAYOUT BOTTOM VIEW

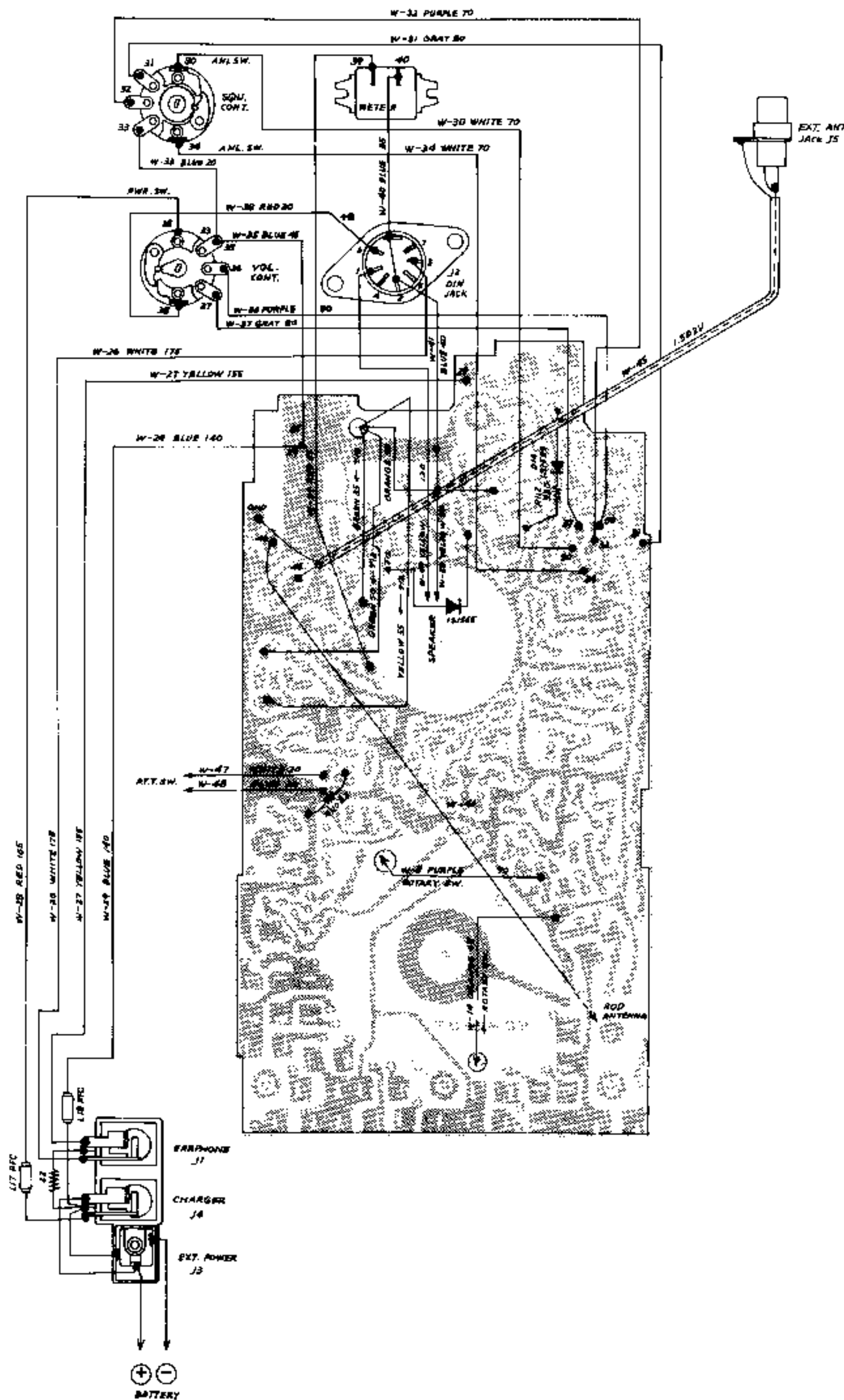

PARTS LIST for TS-5632

DESIGNATION	PARTS NAME	PARTS NO.
MP-5601	Cabinet Front	492023
MP-5602	Cabinet Top	493037
MP-5603	Cabinet Back	492021
MP-5604	Cabinet Cover for BATT.	493039
MP-5605	Speaker Grill	493038
MP-5606	Bushing for Rod Antenna	494205
MP-5607	Knob for VOL/SQU Control	494199
MP-5608	P. T. T. Button Assembly	494200
MP-5609	Cabinet Bottom Plate	494198
MP-5610	Mounting Bracket for Rod Antenna	494202
MP-5611	Cap for EXT. ANT. Jack	494204
MP-5612	Frame for P. C. B.	494196
MP-5613	Heatsink for 2SC1237	494215
MP-5614	Mounting Bracket for Microswitch	494216
MP-209	Mounting Bracket for Speaker	474009
MP-5615	Brand plate	494212
MP-5616	P. T. T. Button Plate	494211
MP-5617	VOL/SQU Plate	494208
MP-5617	Toggle Switch plate	494210
MP-5619	Back plate	494213
MP-5620	DIN type Jack plate	494209
MP-5621	Channel Indicator plate	494231
MP-5622	Battery Case Holder	494207
MP-5623	Supporter for P. C. B.	494227
MP-5624	Speaker Net	494229
MP-5625	Rod Antenna Cover	494219
MP-5626	Knob for Channel Selector	494226
PP-5601	Carrying Case	CC-5632
PP-5602	Instruction Manual	IM-5632
PP-5603	Gift Box	GB-5632
AP-5601	Plug for EXT. Power Jack	S-H4001
TR1	FET	2SK40
TR10	Transistor	2SC735 Y
TR14, 9	Transistor	2SA562 Y
TR19, 15	Transistor	2SC496 Y
TR13	Transistor	2SA496 Y
TR20	Transistor	2SC1237
TR7	Transistor	2SC900E
TR6, 8	Transistor	2SC945Q
TR2, 3, 4, 5, 11	Transistor	2SC839E
12, 16, 17, 18		

PARTS LIST for TS-5632

DESIGNATION	PARTS NAME	PARTS NO.
IC-2	IC.	NE-555V
IC-1	IC.	BA-501
D2,3,4,6,7,8,10,13,15	Silicon Diode	IS-1555
D9, 12	Silicon Diode	IN-4002
D5	Silicon Diode	M8513A
D14, 11	Zener Diode	WZ-110
D1	Germanium Diode	1N60
MF	Ceramic Filter	CFU-455H
VR1	Variable Resistor (Volume) 50K ohm	13-50KAS
VR2	Variable Resistor (Squelch) 10K ohm	13-10BBS
SW3	Micro Switch (P. T. T.)	SS-5
SW2	Toggle Switch	8A2051
J2S	DIN Type 7P socket	CS279
J2P	Shortening Circuit plug for DIN Socket	CP109
SW1	Rotary Switch	S322232
X1~X16	Crystal Oscillator Unit	
EP-301	Crystal Socket	XS-1P
J5	External Antenna Jack	RCA1P
SP	Speaker 57mm 320ohm IMP.	57P-15-7
J1, 3, 4	Tri Jack	C-G-0112-02
T12	Output Transformer	T-1632
M	Meter	21A002
ANT	Rod Antenna	A-32
EP-500	Battery Case UM-3 x 10	BC3-10
T13	Microphone Transformer	T-5632M
T1	27 MHz RF Coil	011-901
T2, 11	27 MHz RF Coil	011-902
T3, 4	10.7 MHz IF. Coil	011-904
T5	455 MHz IF. Coil 1st	011-905
T6	455 MHz IF. Coil 2nd	011-906
T7	455 MHz IF. Coil 3rd	011-907
T8	37 MHz OSC Coil	011-908
T9	TX. Filter Coil	011-909
T10	TX. Filter Coil	011-910
L11	TX. Drive Coil	011-911
L12	RX. Tuning Coil	011-912
L13	RX. Tuning Coil	011-913
L14	ANT. Loading Coil	011-914
L15, 16	RF Choke Coil	005-903

SPECIFICATIONS

GENERAL:

Dimensions	230 (h) x 78 (w) x 43.5 (d) mm
Weight	800 grams without batteries
Powersupply	8 penlight dry cells (12 volts) or 10 penlight rechargeable nickel-cadmium batteries (12.5 volts) or 12 volt external DC supply.
Power consumption	Receive mode (standby) 8mA Receive mode (full audio) 60mA Transmit mode (w/o Mod.) 380mA Transmit mode (w full Mod.) 750mA
Cabinet	Aluminium die cast front and high impact ABS back
Channels	32 channels with all crystals supplied
Controls	volume; squelch; ANL; standby; operate; call; channel
Microphone	internal microphone/speaker combination
Semiconductors	2 integrated circuits; 19 transistors; 1 FET; 15 diodes
Special Features	Electronic T/R switching; 32 channels; standby battery saver; switchable automatic noise limiter; S, power and battery meter; exchangeable antenna; full accessory connector for remote operation.

RECEIVER:

Frequency range	26.965 to 27.275 MHz in 10 KHz steps
Sensitivity	0.5 µV for 10dB S + N/N and 100 mW output at 30% 1KHz modulation
Selectivity	6KHz at -6 dB
Adjacent channel rej	better than 50 dB average
Audio output at 10%	250 mW
Spurious response	more than 50 dB down
Intermodulation	more than 50 dB down
Crossmodulation	more than 50 dB down
Squelch sensitivity	less than 0.1 µV
Noise limiter	automatic series gate

TRANSMITTER:

Frequency range	26.965 to 27.275 MHz in 10 KHz steps
Input power	5 Watt
Modulation capability	100 %
Modulation distortion	less than 5% at 95% modulation
Frequency tolerance	1,200 Hz at -20 to +50 degrees C
External Ant.	50 ohm