

SPECIFICATIONS FOR TS 280 FM

General	
Frequency Coverage:	144.000 to 145.975 MHz in 25 KHz steps.
Frequency control:	Digitally synthesized, low sideband noise PLL system.
Frequency stability:	3×10^{-6} at 25°C 8×10^{-6} at -10 to +50°C
Semiconductor complements:	31 Transistors, 3 FETs, 7 ICs, 2 LED displays, 34 diodes.
Modulation Type:	FM
Supply Voltage:	10-16 VDC
Current drain:	Transmit: 8A at 14 Volts Receive: 300mA at 14V
Antenna Impedance:	50 Ohms unbalanced
Size:	58mm x 156mm x 290 mm (excluding controls)
Weight:	2.3 kg
Transmitter:	
Frequency Control:	Phase Locked Loop synthesizer
Modulation:	FM
Audio Input:	600 Ohms
Microphone:	600 Ohms dynamic
Power Output:	min. 45 Watts at 14 Volts (75 watts input)
Spurious and Harmonic Output:	less than -30dBm. (-70 dB below carrier)
Duty Cycle:	100% transmit at 16V/+60% C 50 Ohms resistive load
Receiver	
Frequency Scheme:	Dual conversion superheterodyne with 10.7MHz and 455 KHz IF
Sensitivity:	+4 μ V for 12dB sinad. -1 μ V squelch threshold
Spurious Response:	-70 dB
Selectivity:	15 KHz -3dB; 25 KHz -70dB
Audio Output Power:	2 Watts at 8 Ohm at less than 10% THD.

SOMMERKAMP ELECTRONIC SAS

CH-6903 LUGANO, P.O. BOX 176

SWITZERLAND

TEL. (91) 688543 TELEX 79314

SOMMERKAMP ELECTRONIC



80 CHANNEL PLL 75 WATTS FM-TRANSCEIVER WITH DIGITAL TUNING



**MODEL TS 280 FM
2m VHF MOBILE**

INSTRUCTION MANUAL

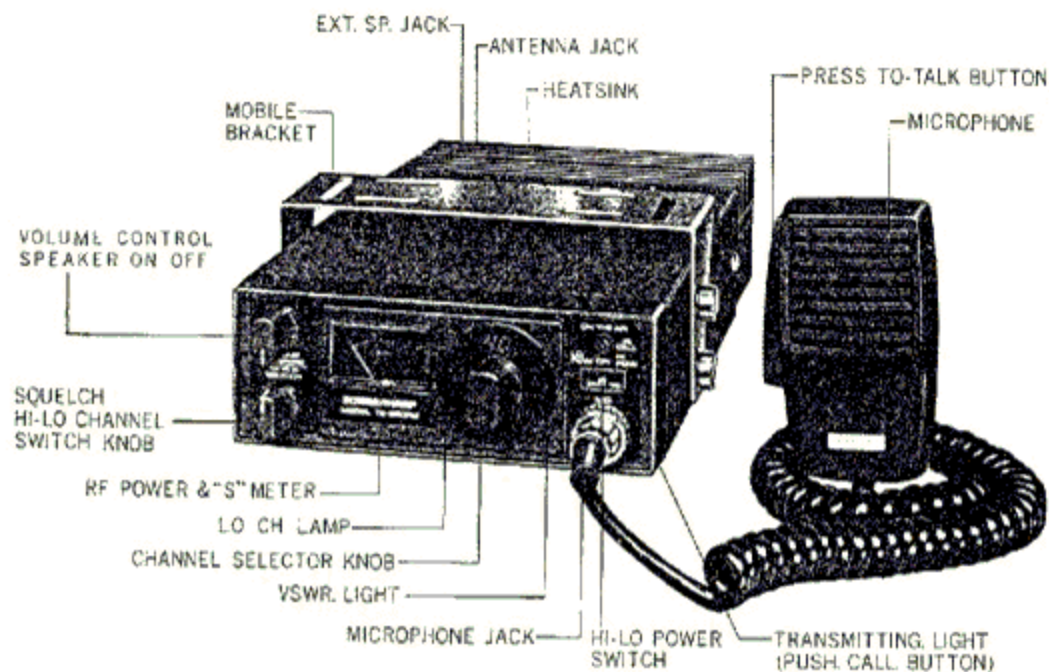

GENERAL DESCRIPTION

The SOMMERKAMPTS280FM is a 75 Watts input frequency synthesized solid state radio set designed for transmission and reception over the 144-146 MHz range. Frequency control employs state of the art digital circuitry combined with a precision phase-locked VCO to provide 80 transmit and receive channels in 25 KHz increments. The operation channel number is displayed by large, bright LED numerics. A unique feature of the TS280FM is its receive frequency flexibility wherein standard repeater splits of 600 KHz can be accommodated. Your SOMMERKAMP TS280FM Transceiver has been designed for continuous heavy duty mobile and base station application. It can be operated with a microphone and internal speaker or handset, speaker-microphone combination, telephone set incorporating automatic voice operated transmit/receive switching, external selective call with automatic answer-back PARROT 76 and many more.

RECEIVER SECTION

The receiver section is designed to receive frequency or phase modulated signals in the 144-146 MHz (2m-amateur) band. The unique combination of low noise field effect transistors (FET's), double conversion, a combination of mechanical-ceramic and L/C-filters, integrated limiting amplifier and discriminator and a hi-fi quality speaker amplifier will provide exceptional reception quality in this fine piece of equipment.

In addition, the above combination of the latest technology provides a sensitivity and unwanted signal rejection and noise suppression available previously only in space and military communication equipment.

The power supply of the receiver, RF-, IF- and second oscillator/mixer section is stabilized by an extremely sharp cut-off Zener diode in conjunction with a series regulator to obtain the high sensitivity and unwanted signal rejection. The high squelch sensitivity is achieved by using a separate noise amplifier detector and switching circuit with carefully balanced hysteresis. The transformerless hi-fi quality audio power amplifier will drive any load between 8 Ohms and indefinite such as internal speaker or external speaker/microphone or headset combination having the above impedances. The meter indicates the field strength during reception of a signal.

The PLL section consists of a C-MOS IC incorporating a reference crystal oscillator, 10 Bit divider chain and 8 Bit programmable binary counter and an edge-type phase detector, voltage controlled oscillator, limiting amplifier and balance mixer, down conversion oscillator and voltage regulators. In addition, the PLL unit contains the lock detector circuit, modulation amplifier and limiter.

TRANSMITTER SECTION

The output signal of the PLL unit is amplified and multiplied to 134 MHz. This signal is mixed with 10.7 MHz and the resulting signal is amplified in the pre- and power amplifier of the transmitter section. The output of the final power amplifier is fed via a matching network, low pass filter and antenna switch to the antenna jack. Between the low pass filter and the antenna jack an SWR bridge detects the standing wave ratio on the antenna cable. If too high, it switches off the transmitter to protect the power amplifier.

RECEIVE/TRANSMIT SWITCHING

The receive/transmit switching is done by a single pole, single throw switch located in the microphone or telephoneset as well as a combination of NPN and PNP switching transistors which function also as voltage regulators.

METER

The meter provides the following combined functions:
In the receive mode it indicates the incoming signal strength, in the transmit mode it shows relative output power.

INSTALLATION

Unpacking:

Remove the transceiver carefully from the packing carton and examine it for external shipping damage. It is recommended to keep the shipping carton for future storage, moving or re-shipment.

Location:

The placement of the transceiver in the vehicle is not critical and should be governed

by convenience and accessibility. Since the unit is very compact, there should not be any difficulties in finding a suitable location for it. Any place where it can be easily mounted with metal screws, bolts or pop-rivets will do.

For base-station operation, the mounting bracket will place the controls at a comfortable level and the built-in speaker into an efficient position.

POWER REQUIREMENTS

Voltage in excess of 16.0 Volts will cause heavy damage to the TS 280 FM. Check the supply voltage before connecting the power cord.

The TS 280 FM is supplied ready for operation from any regulated 13.8 Volts DC, 8.0 Amps. negative ground source. Any vehicle system, 12.0 Volts, negative ground is usually more than adequate. Note however, that problems such as low battery, worn generator/alternator, poor voltage regulator etc. will impair the mobile operation of the TS 280 FM as well as the vehicle itself.

It is recommended that the DC power cable supplied with the set be wired directly to the vehicle battery terminals. Be certain to observe the correct polarity. RED wire is POSITIVE (+) whereas the BLACK wire is NEGATIVE (-). Do not attempt to install the TS 280 FM in a vehicle employing POSITIVE GROUND ignition system. Where a temporary mobile installation is made by connecting the power cable for instance to the cigar lighter, only less than full performance of the TS 280 FM can be expected.

In selecting a base station power supply it is imperative that the unit be sufficiently regulated so that its no-load voltage never exceeds 16.0 Volts and its voltage at a 8.0 Amps load would not drop below 10.0 Volts. The output hum and ripple should be less than 100 millivolts.

ANTENNA

The most important single item that will influence the performance of any communication system is the antenna. For that reason, a good, high-quality antenna of 50 ohms impedance is recommended. When adjusting your antenna, whether mobile or fixed, by all means follow the manufacturer's instructions. There are some pitfalls to be aware of. For example, do not attempt to adjust an antenna for lowest VSWR when using a VSWR meter not engineered for VHF applications. Such readings will invariably be substantial at 145 MHz. Rather, use an in line meter similar to the

Bird Model 23 with VHF cartridge. Further, when adjusting a mobile antenna, do so with the motor running preferably above normal idling speed. This will insure proper voltage level to the transceiver.

Do not become alarmed if your transceiver fails to transmit at times during the antenna tune up procedure. Remember, your transceiver has a built-in Automatic Protection Circuit (APC) that will disable the transmitter if excessive VSWR, or an open or shorted coaxial line or connector, or other antenna deficiency is present.

The RF coaxial connector on the rear chassis mates with a standard PL-259 connector.

MICROPHONE or TELEPHONESET

A high quality dynamic microphone or telephoneset is supplied with the transceiver. Merely plug it into the proper receptacle on the front panel. Should you want to use a different microphone, make certain it is of low impedance type (600 ohms). Particular care should be exercised in wiring as the internal electronic switching system is dependant upon it. See the schematic for the proper hook up. Under no circumstances use a "gain pre-amp" type microphone. The audio system in your transceiver is more than adequate and additional pre-amplification is unnecessary. To use this class of microphone is to invite distortion and unsatisfactory operation of the transceiver.

BUILT-IN SPEAKER/TELEPHONESET SWITCH:

By pulling the volume control knob, the built-in speaker will be disconnected and earphone piece of the telephoneset will be connected. By pushing it back, the built-in speaker will be reconnected again and the earphone piece of the telephoneset will be disconnected.

OPERATING INSTRUCTIONS

After completing the installation as described above switch the transceiver ON by moving the power switch to position HI. The receiving meter and the channel numbers will light up. Turn the squelch control to minimum. Turn the volume control to maximum until you hear a hissing sound. Switch the channel selector to channel 1. Press the transmit button of the microphone or telephoneset and check that the meter needle is near the red mark during transmitting. Release the PTT button and switch to channel 2. Repeat this procedure until all 40 HI and Lo channels are checked out. Then switch to a channel where there is a transmitting station, wait until this station stops to transmit and turn the squelch control slowly to maximum until the background noise just disappears. When the station starts to transmit again you will hear the station, but you will not hear the background noise during its non-transmitting periods.

To send out a call just push the CALL-button. This will transmit automatically a 1750 Hz signal to open repeaters etc. In case the antenna is mis-matched the automatic protection circuit operating the protection lamp will light up. This can be re-set by switching off the transceiver with the POWER switch. For short distance Qso's use the Lo power position.

LIST OF CHANNEL FREQUENCIES

CH. NO.	LOW. CH. (TX. RX.)	HIGH. CH. (TX.)	HIGH. CH. (RX.)
1	144.025	145.025	145.625
2	050	050	650
3	075	075	675
4	100	100	700
5	125	125	725
6	150	150	750
7	175	175	775
8	200	200	800
9	225	225	825
10	250	250	850
11	275	275	875
12	300	300	900
13	325	325	925
14	350	350	950
15	375	375	975
16	400	400	1000
17	425	425	1025
18	450	450	1050
19	475	475	1075
20	500	500	1100
21	625	625	145.625
22	550	550	145.650
23	575	575	145.675
24	600	600	145.700
25	625	625	145.725
26	650	650	145.750
27	675	675	145.775
28	700	700	145.800
29	725	725	145.825
30	750	750	145.850
31	775	775	145.875
32	800	800	145.900
33	825	825	145.925
34	850	850	145.950
35	875	875	145.975
36	900	900	146.000
37	925	925	146.025
38	950	950	146.050
39	975	975	146.075
40	1000	1000	146.100

MHZ

INTERCONNECTION WIRING DIAGRAM

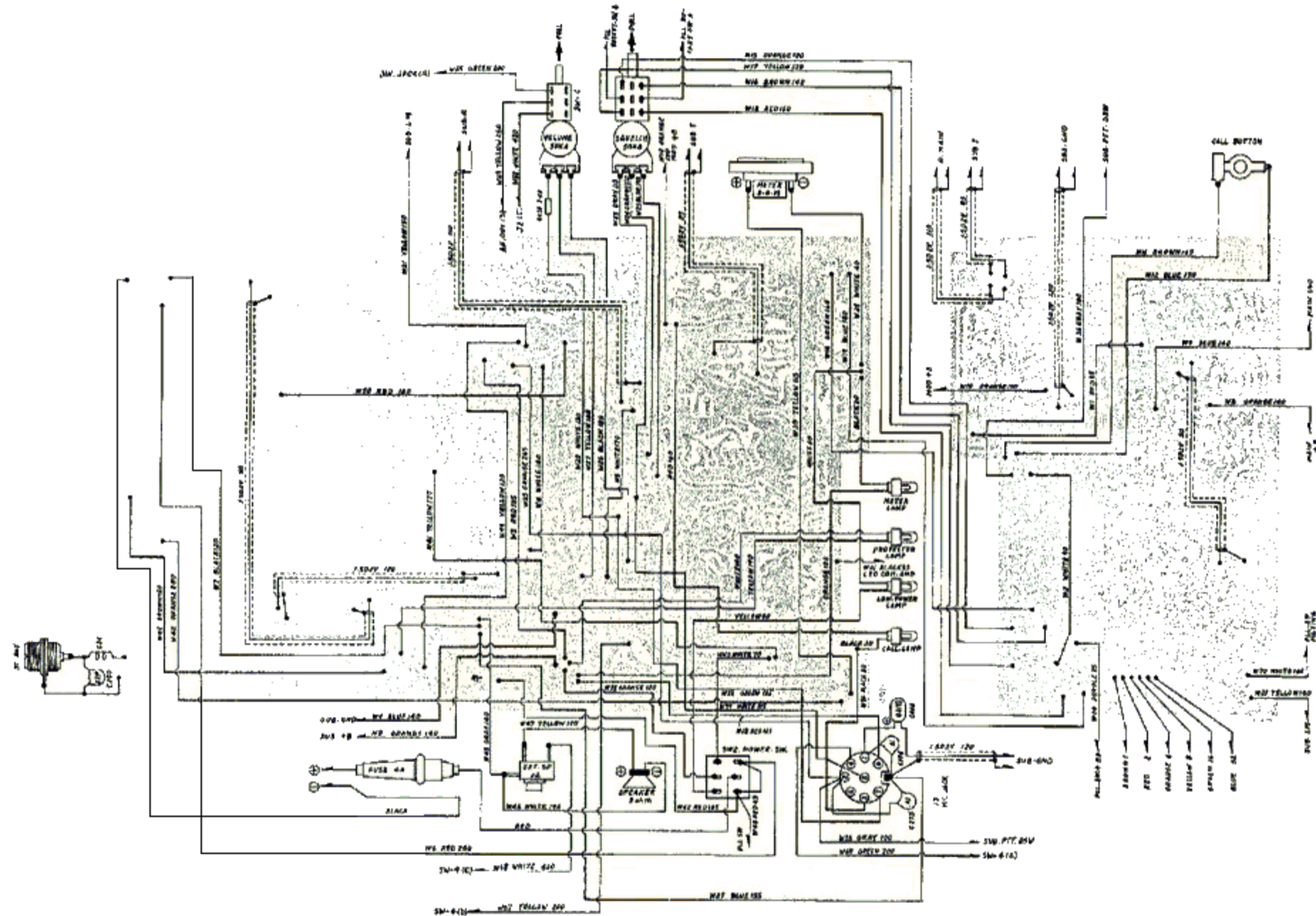

MAIN CHASSIS PRINTED CIRCUIT BOARD PARTS LAYOUT

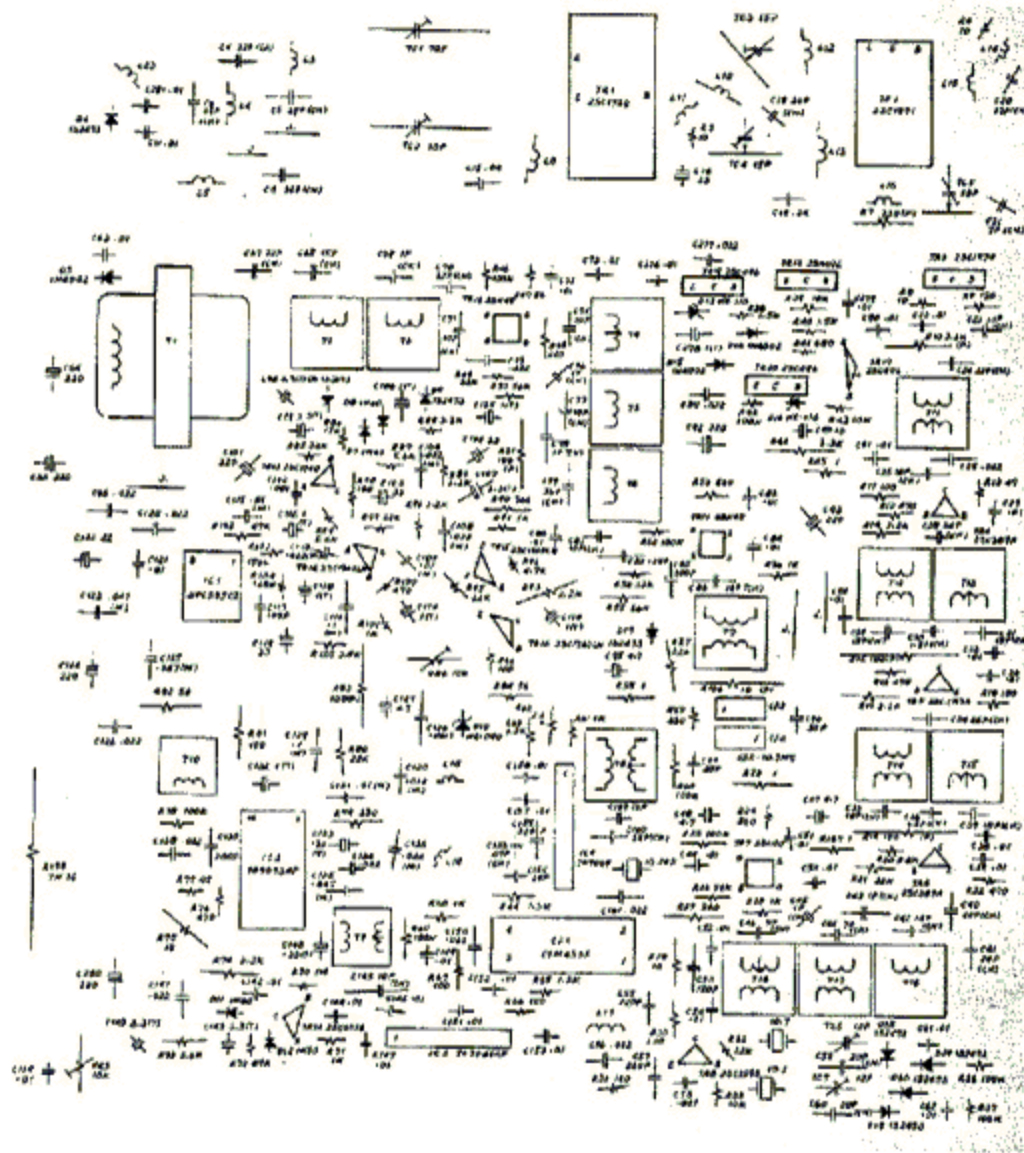

PLL AND BOOSTER ASSEMBLY PARTS LAYOUT

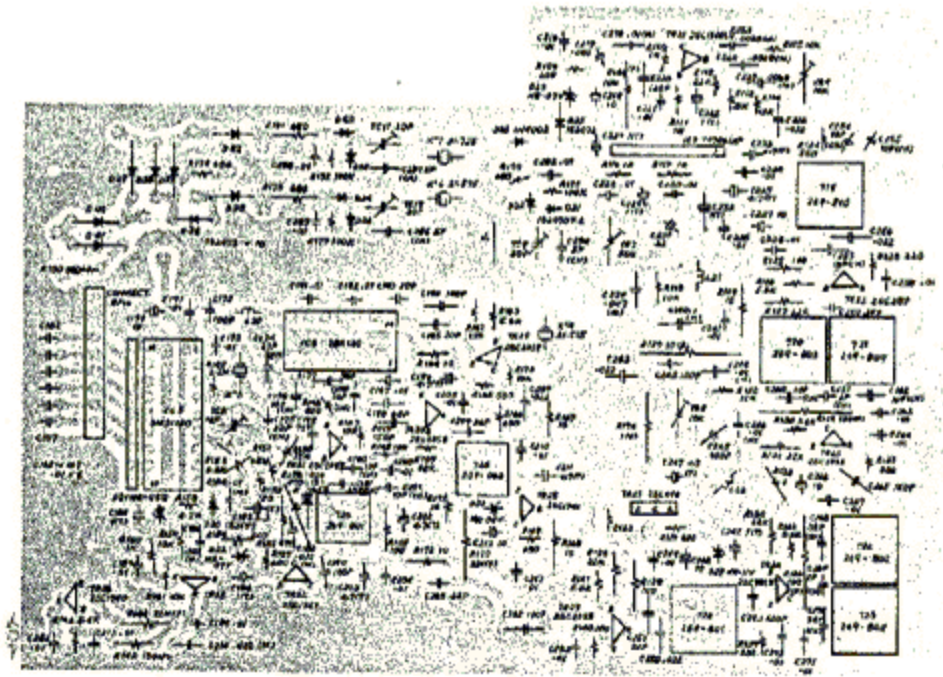
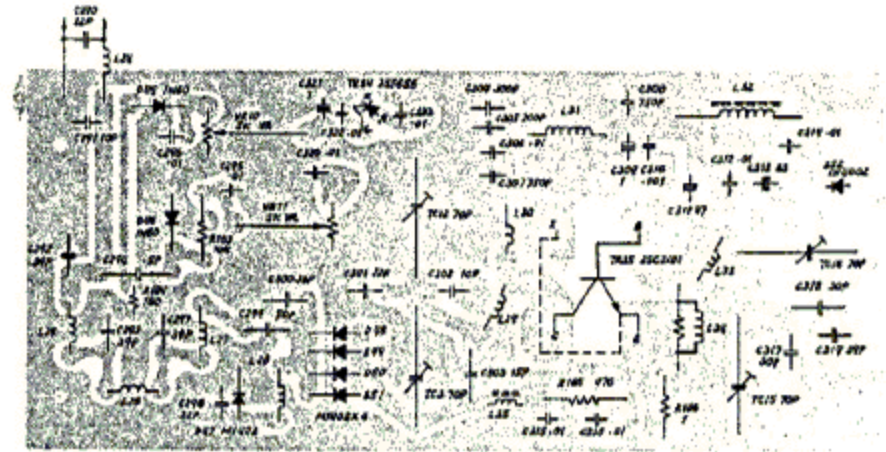

LED DISPLAY INTERCONNECTION WIRING DIAGRAM

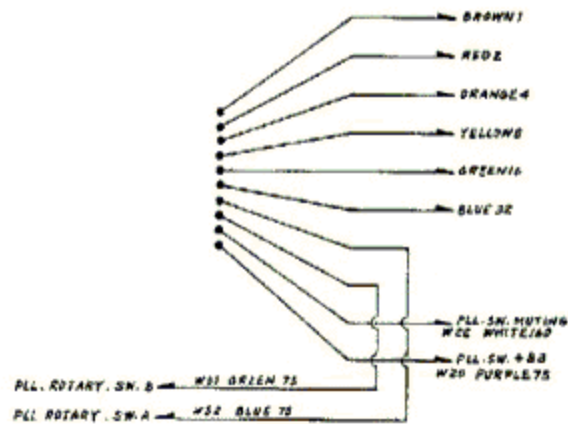
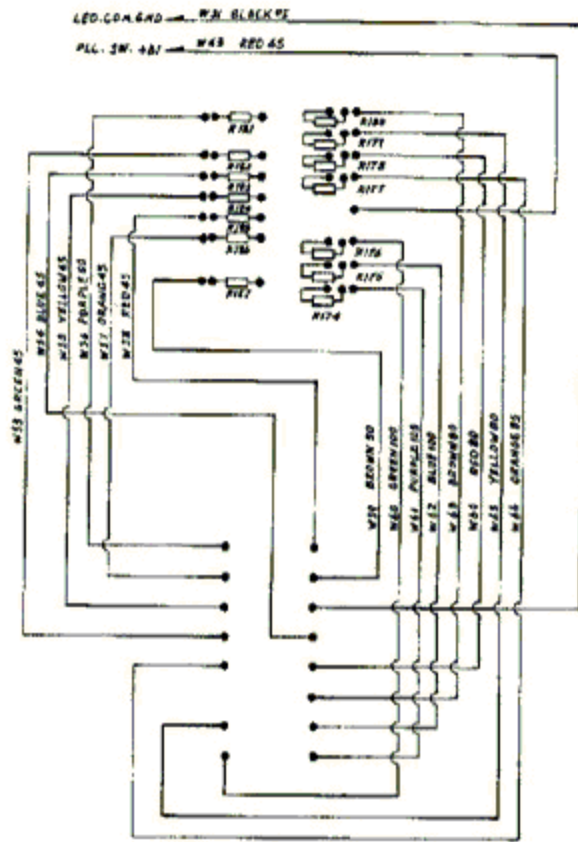

MAIN CHASSIS PRINTED CIRCUIT BOARD COMPLETE PARTS LAYOUT

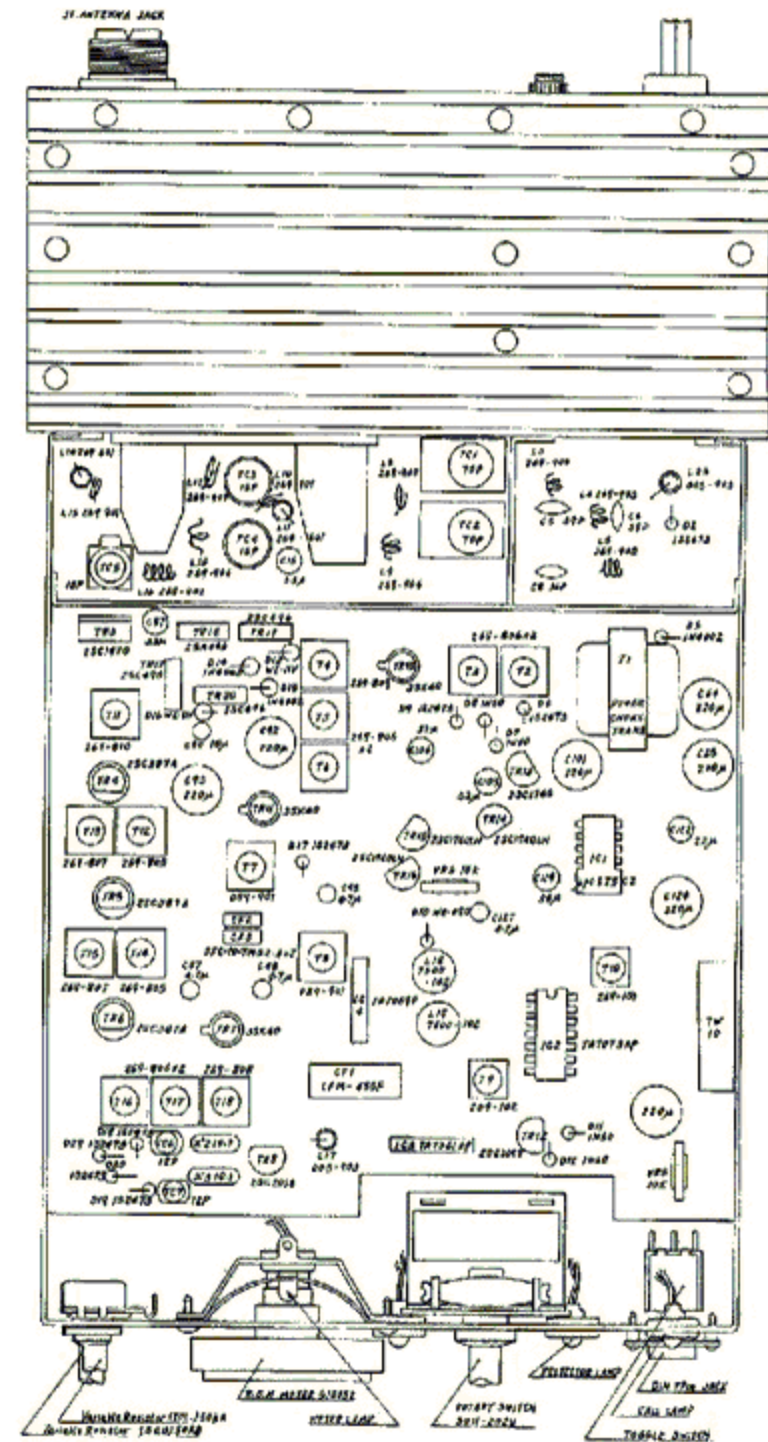

PLL ASSEMBLY
COMPLETE PARTS LAYOUT

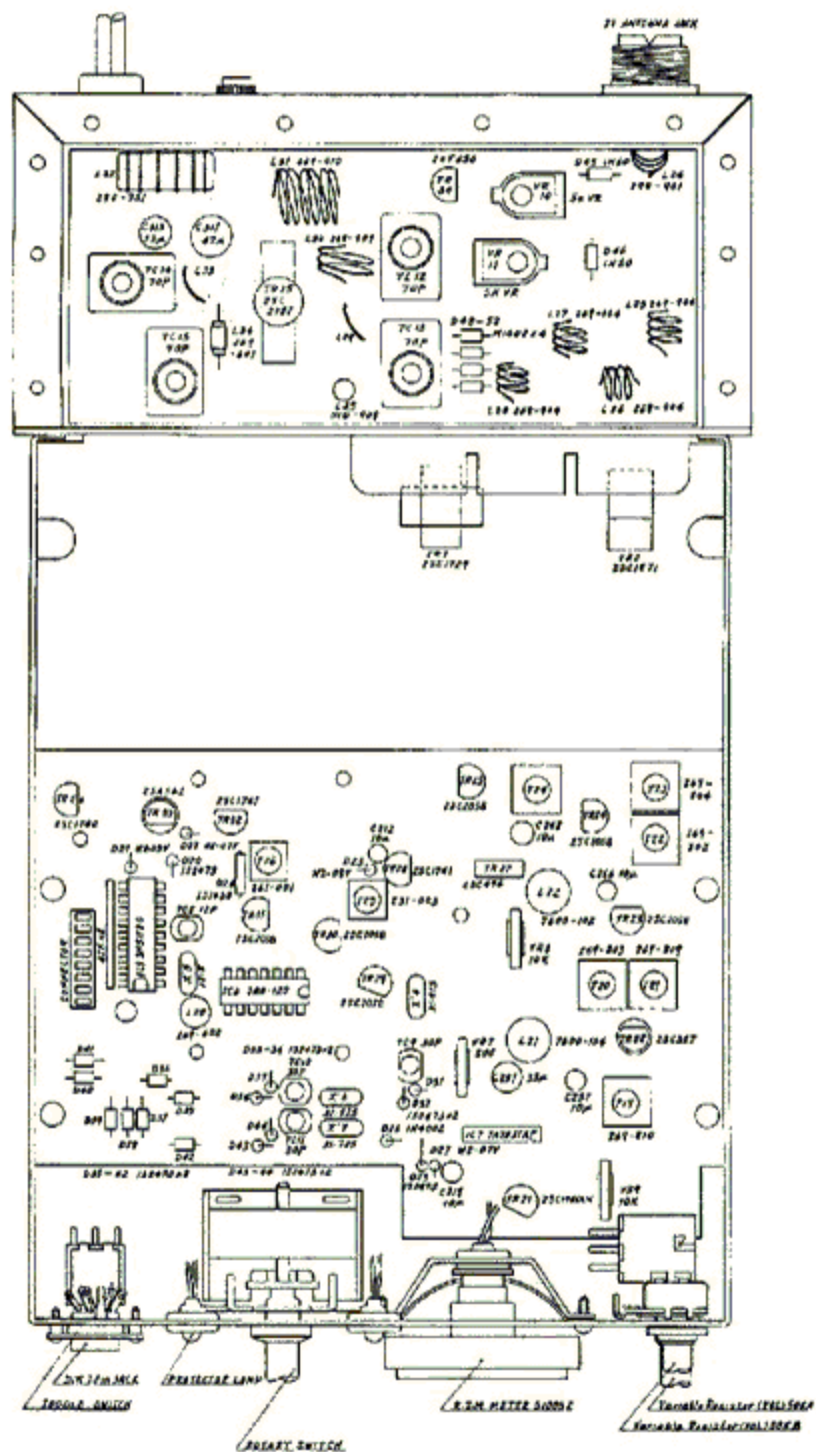

PARTS LIST for TS-280FM

DESIGNATION	PARTS NAME	PARTS NO.
IC1	Integrated Circuit	UPC575C2
IC2	Integrated Circuit	TA7073AP
IC3, 7	Integrated Circuit	TA7061AP
IC4	Integrated Circuit	TA7069P
IC5	Integrated Circuit	SM5118G
IC6	Integrated Circuit	TBA120
TR1	Transistor	2SC1729
TR2	Transistor	2SC1971
TR3	Transistor	2SC1970
TR4, 5, 6, 22	Transistor	2SC387 - A
TR17, 19, 20, 27	Transistor	2SC496 - Y
TR18	Transistor	2SA496 - Y
TR33	Transistor	2SA562 - O
TR8, 12, 23, 24, 25 29, 30, 31	Transistor	2SC2058P
TR28, 32	Transistor	2SC174 - P
TR13, 26	Transistor	2SC1740 - S
TR14, 15, 16, 21	Transistor	1740LN
TR35	Transistor	2SC2181
TR7, 10, 11	FET	3SK40
TR34	SCR	2SF656
D2, 6, 9, 17-20 29-44	Silicon Diode	1S2473
D5, 14, 15, 26, 52	Silicon Diode	1N4002
D7, 8, 11, 12, 45, 46	Germanium Diode	1N60
D13, 16, 28	Zener Diode	WZ - 110
D10, 23	Zener Diode	WZ - 090
D22, 27	Zener Diode	WZ - 070
D21	Zener Diode	WZ - 050
D24	Varicap Diode	1S1658
D47-51	RF. SW. Diode	MJ - 402
R. S. M.	Meter	510052
MIC.	Microphone Complete	22-256-28
K.	Connector 8pin	524438
PL1-4	Pilot Lamp 14V 80mA	524433
SW2	Toggle Switch	8A - 2011
SW3	(Binary) Code Switch, Repeater Switch	SRH - 202U
LED	LED Display	GL - 6P202
SP.	Speaker	T - 75 - 8 - 1
CF1	Ceramic Filter	CFM - 455F
CF2, 3	Ceramic Filter	SFE - 10.7MS2 - A

PARTS LIST for TS-280FM

DESIGNATION	PARTS NAME	PARTS NO.
T1	Power Choke Transformer	EI-24
T2,3,5,6,16,17	RX. RF IN/RX. RF OUT/TX. Mixing Coil	269-806
T4, 21	RX. RF OUT/RX 134 MHz Doubler	269-809
T7, 8	RX. 1st Mix. 10.7MHz	089-901
T9	RX. 455 KHz	269-102
T10	RX. 455 KHz DET.	269-101
T11, 19	TX. 145MHz Drive Coil/RX. 134MHz Buffer Coil	269-810
T12, 14	TX. 145MHz Pri. Drive Coil/Tx. 145MHz Buffer Coil	269-805
T13, 15	TX. 145MHz Pri. Drive Coil/TX. 145MHz Buffer Coil	269-807
T18	TX. Mixing Coil	269-808
T20	RX. 134MHz Doubler	269-803
T22	TX. 67 MHz Doubler	269-802
T23	TX. 67 MHz Doubler	269-804
T24	TX. 33MHz Buffer Coil	269-801
T25	VCO 33 MHz Buffer Coil	231-003
T26	VCO 33 MHz OSC Coil	269-001
L3, 4, 5	L. P. F.	269-905
L8, 12	TX. Final Tune Coil/TX. Drive Tune Coil	269-907
L9, 25 ~28	TX. Final Choke Coil	269-904
L10, 15	TX. Final IN PUT/Tx. Drive IN PUT	269-901
L11, 14, 34	L. R. P.	269-601
L13	RF Choke Coil	269-908
L16	TX. Pri. Drive Tune Coil	269-902
L17, 23	10.7MHz L. P. F. RFC Coil	005-903
L18, 19, 22	1mH Choke Coil	7600-102
L21	100mH Choke Coil	7600-104
L20	50 μ H PLL Mix. Filter Coil	269-602
L24	L. P. F. Coil	299-901
L32	1mH Line Filter Choke Coil	280-701
L35	2.2 μ H Final RF Choke Coil	010-909
TC1,2,12 ~15	Trimmer Final Tune 70PF	AL-70C
TC3, 4	Trimmer Drive Tune 15PF	CVO3A150
TC5	Trimmer Pri. Drive Tune 13PF	CVT-13
TC6, 7, 8	Trimmer X'tal FREQ. 12PF	CVO5C120
TC9, 10, 11	Trimmer PLL LOS. FREQ. 30PF	CVO5E300
J1	Antenna Jack	MRM/INCH
J2	Ext. Speaker Jack	SJ-296
J3	Microphone Jack DIN Type	
F1	Fuse 4A	F-4A

PARTS LIST for TS-280FM

DESIGNATION	PARTS NAME	PARTS NO.
VR1	Variable Resistor (Volume) 50K ohm	VR1650KA
VR2, SW1a, b	Variable Resistor (Squelch) 50K ohm	VR1650KB
VR5, 8	Semi Variable Resistor 10K ohm	SVR010KS3
VR6, 9	Semi Variable Resistor 10K ohm	SVR010KS2
VR7	Semi Variable Resistor 500 ohm	SVR500S3
VR10, 11	Semi Variable Resistor 5K ohm	SVR005K F3
RM	Resistor 47K ohm \times 8	RM8-473K
MP-443	Front Frame	524405
MP-503	Front Plate (R)	524463
MP-519	Front Plate (L)	544621
MP-520	Brand Plate	524459
MP-521	Back Plate	524458
MP-448	Chassis Frame	522060
MP-107	Mounting Bracket	484085
MP-105	Cabinet Cover (Upper)	483016
MP-449	Cabinet Cover (Lower)	523061
MP-450	Back Pannel	524429
MP-211	Meter Lamp Reflection Plate	484063
MP-458	Heatsink	523059
MP-457	Booster Chassis	523060
MP-462	Booster Chassis Cover	524421
MP-353	Heatsink A	494251
MP-451	Heatsink (for 2SC1729, 2SC1971) C	524432
MP-500	PLL Unit Cover (Upper) A	524376
MP-501	PLL Unit Cover (Lower) B	524386
MP-452	Power Unit Cover C	524430
MP-453	Power Unit Cover D	524430
MP-454	Power Unit Cover E	524431
MP-118	Nut for Channel Selector	484073
MP-120	Screw for Mounting Bracket	484098
MP-5	Mounting Bracket for Speaker	474038
MP-506	Mounting Bracket for Speaket	524465
MP-110	Mounting Bracket for Meter	484064
MP-111	Call Switch Contact	484086
MP-112	Call Switch Spring	484087
MP-117	Knob for Channel Selector	484116
MP-17	Knob for Vol./Squ. Control	474011
MP-19	Call Button	484057